

Inductive sensor

Bi1,5-H08K-AP6X-V1131

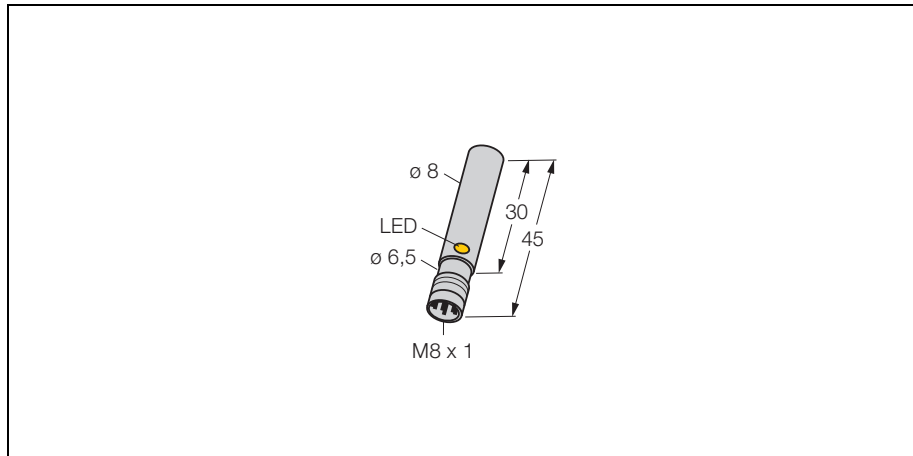

- smooth barrel, 8 mm diameter
- stainless steel, 1.4301
- 3-wire DC, 10...30 VDC
- normally open, pnp output
- connector, M8 x 1

Wiring diagram

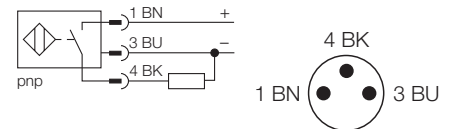

Functional principle

Inductive sensors are designed for wear-free and non-contact detection of metal objects. For this purpose they use a high-frequency electro-magnetic AC field that interacts with the target. Concerning inductive sensors, this field is generated by an LC resonant circuit with a ferrite core coil.

Type	Bi1,5-H08K-AP6X-V1131
Ident-No.	1604330
Rated operating distance Sn	1.5 mm
Mounting condition	flush
Assured sensing range	≤ (0,81 x Sn) mm
Correction factors	St37 = 1, V2A ~ 0.7, Ms ~ 0.4, Al ~ 0.3
Temperature drift	≤ ± 10 %
Hysteresis	3... 15 %
Repeatability	≤ 2 %
Ambient temperature	-25...+ 70 °C
Operating voltage	10... 30VDC
Residual ripple	≤ 10 % U _{SS}
DC rated operational current	≤ 150 mA
No-load current I ₀	≤ 15 mA
Residual current	≤ 0.1 mA
Rated insulation voltage	≤ 0.5 kV
Short-circuit protection	yes / cyclic
Voltage drop at I _e	≤ 1.8V
Wire breakage / Reverse polarity protection	yes / complete
Output function	3-wire, NO, pnp
Switching frequency	≤3kHz
Housing	smooth barrel, 8 mm
Dimensions	45 x 8 mm
Housing material	metal, AISI 304
Material active face	plastic, PA12-GF30
Connection	Connectors, M8 x 1
Vibration resistance	55 Hz (1 mm)
Shock resistance	30g (11 ms)
Degree of protection	IP67
Display switch state	LED yellow

Inductive sensor
Bi1,5-H08K-AP6X-V1131

Mounting instructions	minimum distances
Distance D	2 x B
Distance W	3 x Sn
Distance T	3 x B
Distance S	1.5 x B
Distance G	6 x Sn

Diameter of the active area B	Ø 8 mm
--------------------------------------	--------

